

REVISIONS				
ZONE	REV	DESCRIPTION	DATE	APPROVED
CCITT V.32 14400 MODEM DRY COUPLING				

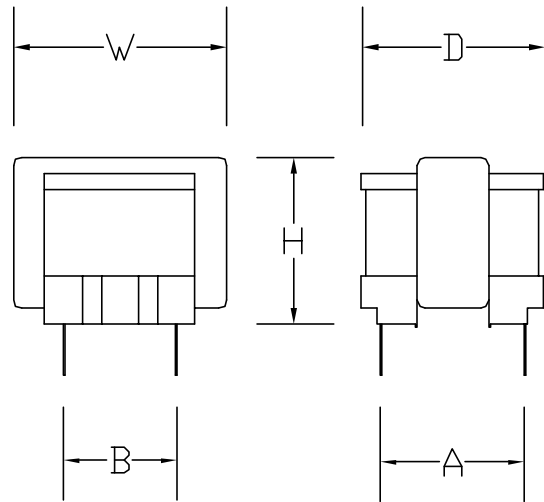

NOTES:

1. IMPEDANCE: REFLECT 600 OHM ON PRI WITH 390 OHM LOAD ON SEC.
2. RETURN LOSS AT 300 & 1000Hz, 21 & 35dB TYP.
3. DC RESISTANCE: PRI=80 OHM +/-10%, SEC=75 OHM +/-10%
4. FREQUENCY RESPONSE AT 200 TO 4000 HZ IS +/- 2.5dB
5. INSERTION LOSS AT 1000 HZ IS 1.6dB
6. DIELECTRIC STRENGTH AT 1500 Vrms 1 MINUTE AT PRI TO SEC & CORE.
7. PRIMARY DC BIAS LOOP CURRENT: 0mA (NONE - DRY CIRCUIT)
8. INDUCTANCE PRI: 350mH AT 1000Hz
9. TURN RATIO: PRI : SEC = 1 : 1 +/- 1%
10. TEST SIGNAL: 1 Vrms AC Peak-To-Peak, 1KHz, 80mA.
11. PRIMARY CURRENT RATING: 80mA.
12. INSULATION RESISTANCE: 500VDC, 1 MEGA OHMS.
13. PIN #1 COLOR MARKING ON BOBBIN.

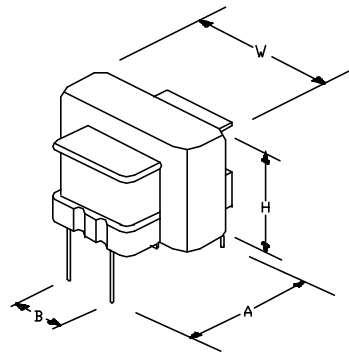
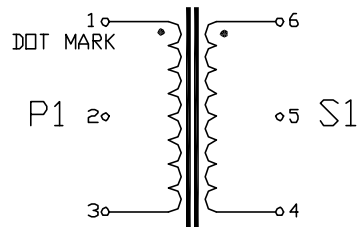

DIMENSION:

W = 0.57" (14.5mm), H = 0.49" (12.5mm), D = 0.55" (14mm)  
 A = 0.43" (11mm), B = 0.28" (7mm)  
 PIN DIA = 0.03" (.8mm) TYP, LENGTH = .2" (5mm), PCB HOLE SIZE = 0.05" (1.2mm),

UNLESS OTHERWISE SPECIFIED: DIMENSIONS ARE IN INCHES TOLERANCES		<b>INTEGRITY TECHNOLOGY</b>			
DECIMALS	ANGULAR				
.XX ± .05	± 0.5°	<b>TELECOM TRANSFORMER</b>			
*XXX ± .010					
DO NOT SCALE DRAWING		SIZE	FSCM NO.	DWG NO.	REV
DRAWN	J. YOUNG	DATE		T14N	M
CHECKED		SCALE	NONE	XTE-T14N	SHEET 1 OF 1
DESIGN					